

75 Gallon UTV Sprayer

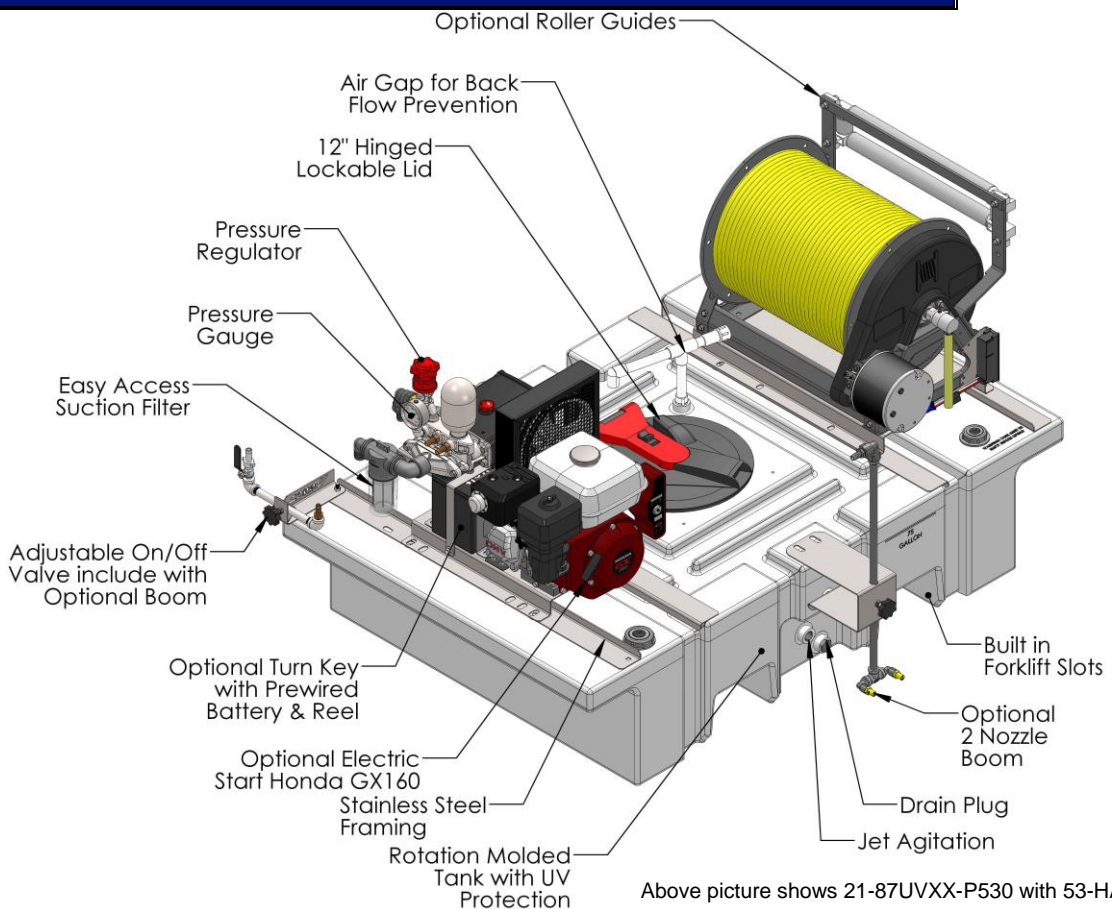

Weight:
 Empty ≈290lbs
 Full ≈950lbs
 Shipping ≈390bs

Min. UTV Payload:
 1,000lb



Above picture shows 21-87UVXX-P530 with 53-HAE1526-1 and 23-850000 Boom

Base Sprayers	Pumps	Max Capacity
21-87UVXX-P530	Piston (Turn Key)	10 GPM / 600PSI
21-87UTXX-P530	Piston	10 GPM / 600PSI
21-87UTXX-KA43	Diaphragm	10 GPM / 560PSI

Reel Packages	Reel	Hose
53-HA1526-0	Hannay 18" Manual	½"X300'
53-HA1526-1	Hannay 18" Manual	¾"X400'
53-HAE1526-0	Hannay 18" Electric	½"X300'
53-HAE1526-1	Hannay 18" Electric	¾"X400'

Call for more Options

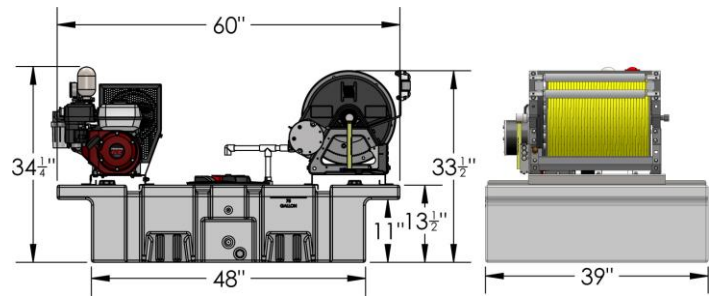

Please note: If the sides of the UTV bed exceed 11", elevate the sprayer by placing boards under the tank.

Optional Accessories	
• Electric Start Engine	• Root Feeders
• Turn Key with Prewired Battery & Reel	• Measuring Wheel
• Quick Discounts	• Ride-On Fill Kit
• Hose Roller Guides	• 2 Nozzle Boom
• Spray Guns	

Call for more options

Standard Features
• 75 Gallon UTV Tank W/ 12" Lid
• Honda GX160 Manual Start Engine
• Stainless Steel Frame
• Jet Agitation
• Easy Access Suction Filter
• Belt Guard (Piston Pump only)
• Lockable Lid
• Back Flow Prevention

Hose & Reels Sold Separately in Packages