

25 Gallon Compact Electric

ITEM NUMBER 21-02CPB2-SH

12vdc Pump

5gpm Capacity

- 25 Gallon Compact Tank
- Stainless Steel Frame
- REMCO 5500 5 GPM 12Volt Pump
- Easy Access Suction Filter

- Manual Econo Hose Reel
- 200' of 3/8" Hose
- Air Gap Backflow Prevention
- Wiring Harness

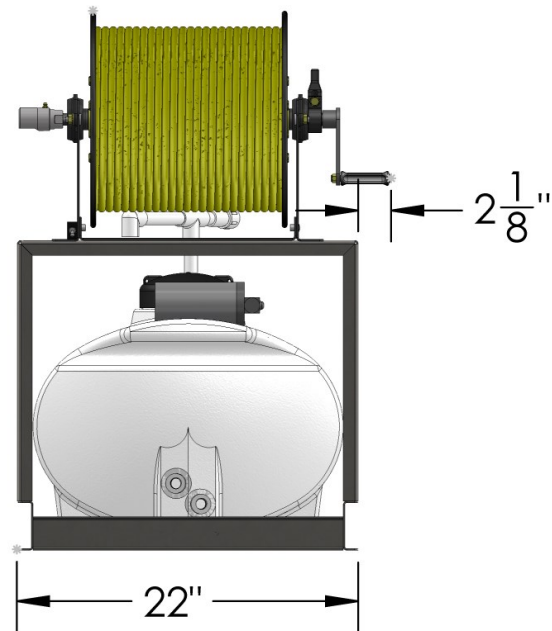
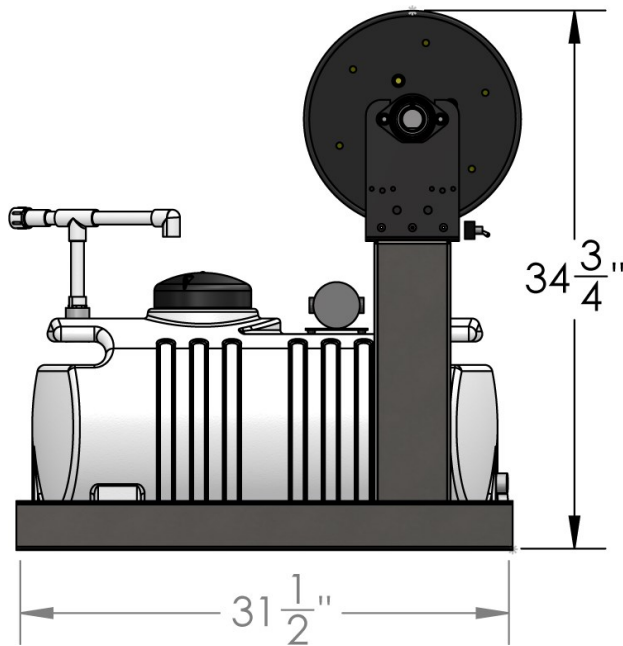

Wiring Harness Included

Accessories

22-210021: Sprayer Cover * 19"H x 46"L x 21"W

