

325 Gallon Poly Skid (15gpm)

ITEM NUMBER 21-83LGXX-P550

Piston Pump

15gpm Capacity

- 325 Gallon Poly Leg Tank w/16" Lid
- Stainless Steel Frame with Risers
- P550 15gpm Piston Pump
- Electric Start Honda GX340 Engine

- Easy Access Suction Filter
- Jet Agitation
- Air Gap Backflow Prevention
- Steel Bands



Base Sprayers	Pumps
21-83LGXX-P550	P550 Piston
21-83LGXX-KA55	Kappa 55 Diaphragm
23-990010	Upgrade P550 to Turn-Key
Reel Packages	Reel & Hose
53-HAE1526-0	Hannay 18" Electric 1/2" x 300'
53-HAE1530-7	Hannay 22" Electric 1/2" x 400'
53-HAE1830	Hannay 22" Electric 3/4" x 150'
HA-9939-1018	18" Roller Guides
HA-9939-1022	22" Roller Guides

Hose Reel and Hose Sold Separately

ACCESSORIES

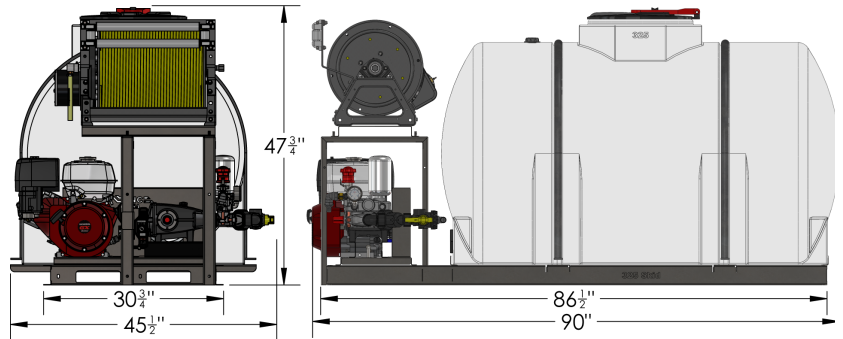

Weight

580 lbs Empty 3290 lbs Full
Approx 650 lbs Shipping