

ROLLER MOUNTING BRACKET
(PRESSED FRAME & ROLL FORM FRAME)
(ITEM 71A FOR "B/B2" ROLLER COMPLETE BRACKET ASSEMBLY)
(ITEM 71B FOR "C/C2" ROLLER COMPLETE BRACKET ASSEMBLY)

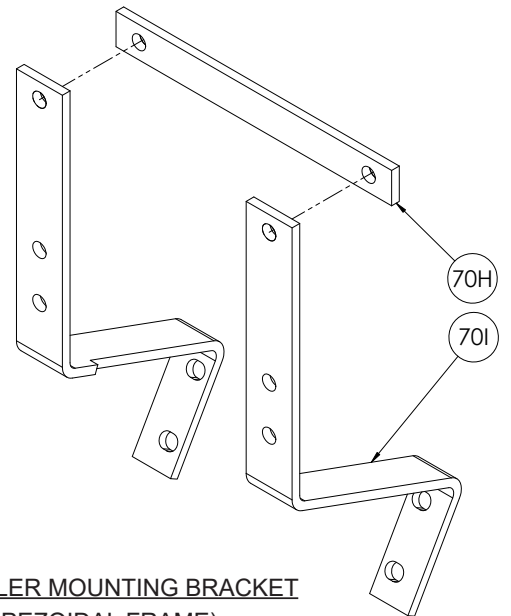

ROLLER MOUNTING BRACKET
(TRAPEZOIDAL FRAME)
(ITEM 71C FOR COMPLETE BRACKET ASSEMBLY)

PARTS LIST
ISO 115
UTILITY HOSE ROLLERS
Assembly A / B / C & A2 / B2 / C2

When Ordering Parts
BE SURE TO SPECIFY COMPLETE MODEL NUMBER and SERIAL NUMBER OF REEL
USE PART NUMBER!

<u>Item No.</u>	<u>Description</u>	<u>Part No.</u>	<u>Quantity</u>
<u>Utility Roller Parts:</u>			
25B	3/8"-16 x 1-1/4" Spinlock Bolt.....	9904.2203	2
25C	3/8"-16 x 1-1/2" Spinlock Bolt.....	9904.2204	2
27	3/8"-16 Spinlock Nut.....	9904.6200	4
70A	Left Hand Assembly "C2" Roller Mounting Block, per P70A-01540.....	9940.0071	2
70B	Right Hand Assembly "C2" Roller Mounting Block, per P70A-01550.....	9940.0072	2
--	Assembly "C" Mounting Block (plated), per P70A-01160 (Not Shown).....	9940.0076**	4
70C	Trunion Bearing - 1-1/2".....	9940.0007	8
81	1/2" x (Specify Roller Length) SST Roller Rod.....	9940.0009	4
91	1-1/2" O.D. x (Specify Roller Length) SST Roller Tubing.....	9940.0003	4
 <u>Complete Utility Roller Assemblies:</u>			
	Assembly "A" Rollers- Complete (Specify Model).....	9939.0060	
	Assembly "B" Rollers- Complete (Specify Model).....	9939.0061	
	Assembly "C" Rollers- Complete (Specify Model).....	9939.0062	
	Assembly "A2" Rollers- Complete (Specify Model).....	9939.1060	
	Assembly "B2" Rollers- Complete (Specify Model).....	9939.1061	
	Assembly "C2" Rollers- Complete (Specify Model).....	9939.1062	
 <u>Roller Mounting Bracket Parts (Pressed Frame & Roll Form Frame):</u>			
25A	3/8"-16 x 1" Spinlock Bolt.....	9904.2202	4
27	3/8"-16 Spinlock Nut.....	9904.6200	4
70E	Top Wind Welded Cross Brace (Specify Model).....	9941.0046	1
70F	Top Wind Vertical Upright w/ prevision for crank (Specify Model).....	9941.0037	1
70G	Top Wind Vertical Upright w/ no prevision for crank (Specify Model).....	9941.0036	1 or 2
70J	Top Wind Diagonal Brace (Specify Model).....	9941.0301	2
71A	Assy B & B2 Top Wind Mounting Bracket- Complete (Specify Model).....	9941.0041	
71B	Assy C & C2 Top Wind Mounting Bracket- Complete (Specify Model).....	9941.0040	
 <u>Roller Mounting Bracket Parts (Trapezoidal Frame):</u>			
70H	Top Wind Cross Member Brace (Specify Model).....	9941.0034	1
70I	Top Wind Mounting Brackets per P70A-01500 (Pair).....	9941.0033	1
71C	Assy C & C2 Top Wind Mounting Bracket- Complete (Specify Model).....	9941.0035	1

***NOTE:** If Assembly "A", "B", or "C" is chosen instead of Assembly "A2", "B2", or "C2", the mounting block part number changes to 9940.0076.

****NOTE:** Stainless Steel & Aluminum Bracing Available.