

# 300 Gallon Fiberglass Tank Sprayers

## Available in Single Tank or 200/100 Split Tank

These fiberglass tank sprayers offer the benefits of a sleek appearance, UV protection for your chemicals, and ability to handle the rigors of Mechanical Agitation for those heavier chemicals and wettable powders.

- ◆ Ideal for flatbed sprayer trucks.
- ◆ Easy to apply your company logo and advertising.
- ◆ Durable Stainless Steel Frames

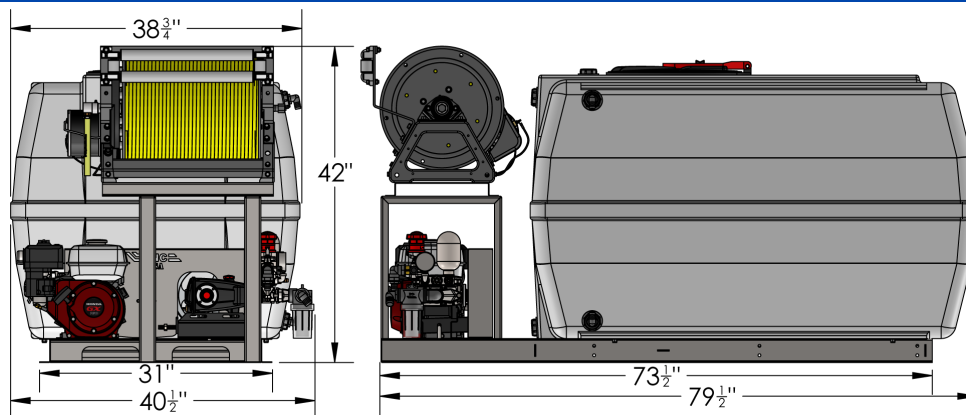

### **300 Gallon 200/100 Split** **21-83FSXX-P530**

- P530 Piston Pump/Honda GX160 Manual Start Engine
- Sight Gauge on Each Tank Side
- Stainless Steel Frame
- Jet Agitation in both tanks

### **300 Gallon 200/100 Split** **21-83FSXX-P550**

- P530 Piston Pump/Honda 11hp Electric Start Engine
- Sight Gauge on Each Tank Side
- Stainless Steel Frame
- Jet Agitation in both tanks

### **Recommended Hose Reel Options:**

#### **Hannay :**

- 18" Elec. 300' 1/2" Hose, 53-HAE1526-0
- 18" Elec. 400' 3/8" Hose, 53-HAE1526-1

### **Options**

- **Turn-Key**
- **Mechanical Agitation**
- D30, D50, or **Other Pumps** Avail.
- **Dual Hose Reels**
- **Electric Start for GX160 Engine**

### **300 Gallon Single Tank** **21-83FGXX-P530**

- P530 Piston Pump/Honda GX160 Manual Start Engine
- Sight Gauge
- Stainless Steel Frame

### **300 Gallon Single Tank** **21-83FGXX-P550**

- P550 Piston Pump/Honda 11hp Electric Start Engine
- Sight Gauge
- Stainless Steel Frame

The "Turn-Key" feature includes an on-board auxiliary battery pre-wired to your electric start engine that will start your sprayer and operate your electric hose reel. This eliminates the need for wiring to your truck plus enables you to move the sprayer from one vehicle to another without additional wiring. The engine will recharge the battery while in use.

*\*Additional battery recharge may be required based upon individual use*

# 300 Gallon Fiberglass Tank Sprayers

*Considered by many as the “Cadillac” of Sprayers*

- Available in Single 300 gallon Tank or 200/100 gallon Split Tanks
- Interior baffles reduce liquid movement
- Standard with jet agitation. Split tanks have agitators in each tank
- Mechanical Agitation Available
- Hinged, lockable lids reduce loss of lids when not secured properly
- Air-gap Backflow Prevention Standard
- Sight Gauge. One on each side of split tank

- Empty Weight 609 lbs (Based on P530 pump/Honda GX160 engine)
- Full Weight 3,111 lbs
- Shipping Weight 650
- Shipping Dimensions 94” x 48” x 57”

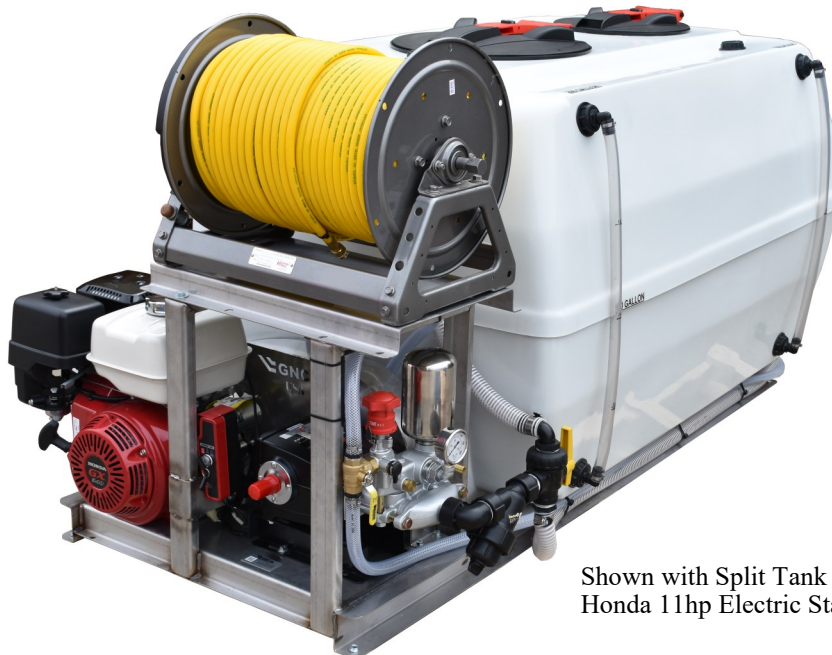

Shown with Split Tank and P550 Pump,  
Honda 11hp Electric Start Engine